



COUNTY OF RIVERSIDE BUILDING AND SAFETY DEPARTMENT

Residential Swimming Pool, Spa, Hot Tub, and Barrier Plan Check Requirements “Barrier Agreement Letter”

This document provides requirements for the residential swimming pool plan review submittal requirements to induce but not limited to minimum standards per the California Building Codes (T-24), Riverside County ordinances, and State/Federal Laws. The following shall be included with all residential swimming pool, spa, and hot tub pool plan submittals:

- A legible and neat site plan showing the following information:
 - Property lines, easements, right-of way of record, abandoned or active oil wells and overhead utilities adjacent to pool are over the property.
 - All existing and proposed structures (covered under this review), such as BBQs, fire bowls, fire pits, slides, grottos, retaining or garden walls, or other relevant characteristics adjacent to the pool/spa, or hot tub.
 - The proposed pool, spa, or hot tub shape shall be dimensioned and located to show property lines setbacks, side yard setbacks, and dimensioned clearances from all existing and proposed structures.
 - Show all proposed mechanical (pool) equipment (including number of pumps) locations with dimensions to all property lines and structures. The equipment locations shall comply with all setback requirements to property lines, adjacent property, and openings to habitable structures.
 - If applicable, show the location of overall height and degree of slope for all ascending and descending lot dimensions from the pool or spa to slope. The pool, spa, or hot tub design shall conform to section 1808.7 of the California Building Code (CBC) for foundation on or adjacent to slopes.
 - Overhead service conductors and open overhead wiring over and near swimming pools and similar installations shall comply with minimum clearances given in article 680.8 and table 680.8A within the California Electrical Code (CEC). Provide details showing conductor clearances over and near the pool.
 - Where construction of stairs is proposed for slides, grottos and similar features, compliance with stair, risers and thread measurements, guards, and handrails, per the California Residential Code (CRC) shall be indicated on the plans.
 - Additional construction details such as slides, raised rock coping, grottos, etc., as well as a complete set of manufacture specifications (fencing, pool covers, and alarms) shall be included with the plan submittal.
 - See our attached checklist for further information required for the plan review.

*Note 1: Non-dedicated electrical and/or gas lines for proposed “future” use are **not** permitted.*

Note 2: A wall permit is required to re-construct a wall, or a section of a wall, that has been (or will be) demolished to accommodate the access of equipment to build the pool.

This Notice will advise you that a permit for a swimming pool has been applied for on your behalf and as owner of the property listed, you should be aware that under the provisions of Riverside County ordinance and SB 442. These requirements apply for construction or installation of all residential swimming pools, spas, and hot tubs: **Compliance with a minimum of two compliant barriers that shall be installed, inspected, and approved prior to the plastering or filling with water.** For your convenience, we have listed a copy of those requirements below:

California Senate Bill 442 & Riverside County Municipal Code 8.28: Barrier Requirements:

Persons in possession of land within the county, either as owner, purchaser under contract, lessee, tenant, or licensee, upon which situates a swimming pool, spa, or similar facility, shall meet the following requirements:

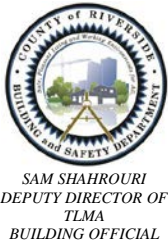

SAM SHAHROURI
DEPUTY DIRECTOR OF
TLMA
BUILDING OFFICIAL

COUNTY OF RIVERSIDE BUILDING AND SAFETY DEPARTMENT

Residential Swimming Pool, Spa, Hot Tub, and Barrier Plan Check Requirements “Barrier Agreement Letter”

Primary Barrier:

1. An enclosure that isolates the swimming pool or spa from the private single-family home, accessory dwelling unit, and/or guest quarters. This may be achieved by:
 - a) Compliant wall/fencing (5' minimum) around the property with compliant gates and exit door alarms on the portion of any dwelling wall that serves as part of a barrier.
 - b) Mesh Fencing is NOT allowed as a primary barrier.

Secondary Barrier:

2. Safety pool covers shall be ASTM F-1346 listed. Where an automatic power cover is installed, the controlling device shall be within line of site of the pool, mounted 54 inches above adjacent grade and within 25ft of the water's edge, or manufactures maximum allowable distance, whichever is shorter.
3. Water/Splash alarms that when placed in a swimming pool or spa, will sound upon detection of accidental or unauthorized entrance into the water. The alarm shall be ASTM F-2208 listed for “standards safety specification for residential pool alarms” which include surface motion, pressure, sonar, etc. alarm types. *Note: an alarm feature designed for individual use, including an alarm attached to a child that sounds when the child exceeds a certain distance or becomes submerged in water, is not a qualifying drowning prevention feature.*
4. Mesh Fencing may be allowed as a secondary barrier and shall be ASTM-F2286 listed.
5. Other means of protection, if the degree of protection afforded is equal to or greater than that afforded by any of the features set forth above and has been independently verified by an approved testing laboratory as meeting the standards for safety features established by ASTM or the ASME.

BARRIER SPECIFICATIONS

Barrier Height and Clearances: Outdoor Swimming Pool – An outdoor swimming pool shall be provided with a barrier that shall comply with all the following:

1. The top of the barrier shall be at least (60) inches above grade, **measured on the side of the barrier that faces away; form the swimming pool.** No natural or artificial grade, rock outcropping or artificial structure or construction may be placed within the (3) foot horizontal distance to the exterior barrier which reduces the barrier height to less than (60) inches.

The maximum vertical clearance between grade and the bottom of the barrier shall be (2) inches measured on the side of the barrier that faces away from the swimming pool. The maximum vertical clearances at the bottom of the barrier may be increased to (4) inches when grade is a solid surface such as a concrete deck, or when the barrier is mounted on the top of the aboveground pool structure.

When barriers have horizontal members spaced less than (45) inches apart, the horizontal members shall be placed on the poolside of the barrier. On the side away from the swimming pool, the barrier shall be free of protrusions, indentations, cavities or cutouts, or other physical characteristics which render the barrier easily climbable.

2. **Chain link fences used as the barrier:** The maximum mesh size for chain link fences shall not be greater than (2-1/4) inches square. All chain link fences shall not be less than (11) gauge, and all chain link fencing shall be permanently installed by tension post/cable connection at the top and bottom for the entire length of the fence, with the support posts installed in concrete footings per industry standards.



COUNTY OF RIVERSIDE BUILDING AND SAFETY DEPARTMENT

Residential Swimming Pool, Spa, Hot Tub, and Barrier Plan Check Requirements “Barrier Agreement Letter”

3. **Access gates:** Shall comply with the requirements of the items above and shall be equipped with a locking device. Pedestrian access gates shall be self-closing and have a self-latching device. Where the release mechanism of the self-latching device is located less than (54) inches from the bottom of the gate, [1] the release mechanism shall be located on the pool side of the barrier at least 3” below the top of the gate, and [2] the gate and barrier shall have no opening greater than (1/2) inch within (18) inches of the release mechanism. Pedestrian gates shall swing away from the pool. Any gates other than pedestrian access gates shall be equipped with either [1] a permanent automatic closing device or system with electrical power source; or [2] lockable hardware or padlocks. These gates shall always remain locked when not in use.
4. Where a wall of a group R-3 (private dwelling) occupancy dwelling unit serves as part of the barrier and contains door openings between the dwelling unit and the outdoor swimming pool that provides direct access to the pool, a separation fence, self-closing self-latching device, or door alarm shall be provided:
 - a) Separation fence is a primary barrier around the pool/spa.
 - b) Self-Latching device shall follow the same requirements stated on #3 above.
 - c) Door Alarm shall be UL-2017 listed by an approved agency and/or follow the following standards:
The alarm shall sound continuously for a minimum of (30) seconds within (7) seconds after the door and its screen, if present, are opened, and be capable of provided a sound pressure level of not less than 85 dBA when measured indoors at (10) ft. The alarm shall automatically reset under all conditions. The alarm system shall be equipped with a manual means, to temporarily deactivate the alarm for a single opening. Such deactivation shall last no longer than (15) seconds. The deactivation bypass button shall be located at least (54) inches above the threshold of the door. Cannot have an on/off switch or tied to a security system.
5. Where an above ground pool structure is used as a barrier or where the barrier is mounted on top of the pool structure, and the means of access is a ladder or steps, then [1] the ladder or steps shall be capable of being secured, locked, or removed to prevent access or [2] the ladder or steps shall be surrounded by a barrier that meets the requirements of items #1 through #4. When the ladder or steps are secured, locked, or removed, any opening created shall be protected by a barrier complying with sections #1 through #4.
6. For an indoor swimming pool, protection shall be provided by 2 of the following safety devices:
Self-closing self-latching device, door alarm, splash alarm, pool cover, following the above requirements.
7. For all other bodies of water over 24” deep, they shall comply with the requirements of section #4.

EXEMPTION: A **self-contained** spa or hot tub equipped with a listed safety cover which complies with ASTM F-1346-91 shall be exempt from all barrier requirements.

NOTE: A pet door (doggie door) shall not have direct access to the pool/spa.

NOTE: Wire fence (critter fencing) is NOT allowed. Wire fencing must meet Chain Link fence requirements.

This must be signed by the owner or his agent and returned to the Building Official prior to permit issuance.

I hereby acknowledge, that I have read and will follow the requirements stated in this handout.

Property Address: _____

Owner/Owner’s Agent (print): _____

Owner/Owners ‘Agent (signature): _____ Date: _____

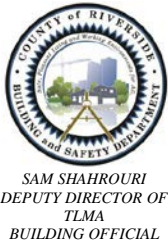

COUNTY OF RIVERSIDE BUILDING AND SAFETY DEPARTMENT

Residential Swimming Pool, Spa, Hot Tub, and Barrier Plan Check Requirements “Barrier Agreement Letter”

Please use the following checklist to help expedite the B&S Plan Check review process.

Yes / No	GENERAL REQUIREMENTS
<input type="checkbox"/> <input type="checkbox"/>	Riverside County “Barrier Agreement” signed by the owner or their authorized agent.
	PRIMARY BARRIER
<input type="checkbox"/> <input type="checkbox"/>	Plans shows a compliant barrier 5’H min. isolating the pool. <ul style="list-style-type: none"> • Plans indicating the barriers material and height at each change in direction.
<input type="checkbox"/> <input type="checkbox"/>	Indicate Door Alarm on the plans and provide a complete “Operation Manual” <ul style="list-style-type: none"> • Required when any portion of the dwelling wall serves as part of the primary barrier.
	SECONDARY BARRIER
<input type="checkbox"/> <input type="checkbox"/>	Plans indicate model #, show secondary barrier at the pool/spa, and a complete “Operation Manual” is provided. <ul style="list-style-type: none"> • Pool Splash Alarm: Show location of the alarms. Must be ASTM-F2208 listed. • Pool Cover: Show location of controlling device. Must be ASTM-F1346 listed. • Mesh Fencing: Plans show location of fence (min. 3’ from water’s edge). Must be ASTM-F2286 listed.
	ELECTRICAL / GAS
<input type="checkbox"/> <input type="checkbox"/>	Plans show conductor and gas lines from point of connection to the pool equipment.
<input type="checkbox"/> <input type="checkbox"/>	Plans show conductor information: Size, length, and breaker size for all electrical supplied devices.
<input type="checkbox"/> <input type="checkbox"/>	Plans show gas line information: Size, type, and length for all gas supplied devices.
<input type="checkbox"/> <input type="checkbox"/>	Plans show pool equipment information: # of pumps, HP, Heater BTU, and pool subpanel size (as applicable).
<input type="checkbox"/> <input type="checkbox"/>	If (2) or more pool pumps are proposed, the following is required: <ul style="list-style-type: none"> • Indicate main service panel size and provide a load calculation to verify it can support the additional loads. • Show location and size of pool subpanel. • Provide manufacture installation instructions or nameplate rating of the pool pump(s) for proper conductor and overcurrent protection sizing. • Provide a panel schedule of the pool subpanel (breaker size and label).
<input type="checkbox"/> <input type="checkbox"/>	Plans show all the following Electrical/Gas notes on the plans: <ol style="list-style-type: none"> 1. All pool equipment provided with GFCI protection (CEC 680.27 &.28). 2. Where the supply line path travels under a structure, the gas line shall be vented per (CPC 1210.1.6). 3. Underground plastic gas pipes shall have a min. #14 “Yellow tracer wire. 4. All gas supplied devices shall have a shut off valve as per (CPC 1212.6). 5. Pipes are part of the pool equipment and any pipes emerging from the ground shall not encroach into the 5ft setback or planning variance will be required.



SAM SHAHROURI
DEPUTY DIRECTOR OF
TLMA
BUILDING OFFICIAL

COUNTY OF RIVERSIDE BUILDING AND SAFETY DEPARTMENT

Residential Swimming Pool, Spa, Hot Tub, and Barrier Plan Check Requirements “Barrier Agreement Letter”

	SITE PLAN / ENGINEERING
<input type="checkbox"/> <input type="checkbox"/>	The pool is designed and stamped by a California Licensed Professional Engineer (Structural / Civil).
<input type="checkbox"/> <input type="checkbox"/>	The engineer of record has certified the site plan has been reviewed for conformance to the structural details.
<input type="checkbox"/> <input type="checkbox"/>	Plans are to be legible, on a minimum 11”x17” sheet and the pool/spa dimensions are shown on the plans.
<input type="checkbox"/> <input type="checkbox"/>	The plan shows how positive drainage will be maintained (tie into existing drains or install drains as required).
<input type="checkbox"/> <input type="checkbox"/>	The site plan identifies the areas around the pool such as: slab, grass, paver, planter, etc., or a combination of. <ul style="list-style-type: none"> If not identified, during inspection the most restrictive equipotential bonding grid shall be installed.
<input type="checkbox"/> <input type="checkbox"/>	If stairs with 4 or more risers are proposed, provide the following: <ul style="list-style-type: none"> Handrail details per (R311.7.8).
<input type="checkbox"/> <input type="checkbox"/>	If a walking surface is located more than 30” vertically from the floor/grade, provide Guard Rail details per (R312.1).
<input type="checkbox"/> <input type="checkbox"/>	Plans show access for field equipment: <ul style="list-style-type: none"> Indicate existing barrier and what will be rebuilt (barrier type and height). Block Walls that are removed and are to be rebuilt, require a BWL permit prior to permit issuance. Or indicate on plans that no Block Wall will be removed during pool/spa construction.
Yes / No	THE FOLLOWING NOTES ARE INCLUDED IN THE SITE PLAN
<input type="checkbox"/> <input type="checkbox"/>	2022 CRC, CEC, CMC, CPC, and the California Energy Code.
<input type="checkbox"/> <input type="checkbox"/>	Equipotential bonding grid to be installed, per the County handout. <ul style="list-style-type: none"> Include handout as part of the submittal package.
<input type="checkbox"/> <input type="checkbox"/>	Enclosure Characteristics: <ul style="list-style-type: none"> Any access gates through the enclosure open away from the swimming pool and are self-closing with a self-latching device placed no lower than 54 inches above the ground. A minimum height of 60 inches. A maximum vertical clearance from the ground to the bottom of the enclosure of two inches. Gaps or voids, if any, do not allow passage of a sphere equal to or greater than four inches in diameter. The garage man door shall be self-closing and self-latching.
	MISCELLANEOUS
Notice:	BBQs require a BXX permit prior to permit issuance OR BPL/BEL for utility lines if BBQ is to be “Future”.
<input type="checkbox"/> <input type="checkbox"/>	Does the BBQ Island require water/sink? If so, connection to the sanitary sewer is required. Add the following note: <ul style="list-style-type: none"> BBQ island sink shall connect to the sanitary sewer.

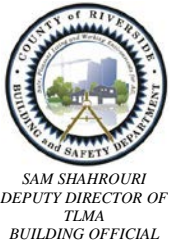

COUNTY OF RIVERSIDE BUILDING AND SAFETY DEPARTMENT

Residential Swimming Pool, Spa, Hot Tub, and Barrier Plan Check Requirements “Barrier Agreement Letter”

The following is a checklist for our typical residential pool/spa inspections.

All inspections under each section must be approved, to move on to the next inspection.

Partial inspections are **NOT** allowed unless specifically indicated below as (partial).

1st Inspection:

- 1) Setbacks / Footings & Forms – Steel & Hardware – Ground Plumbing – Conduit – Yard Line Gas Test.
 - a) Verify Setbacks, Rebar per structural, 4 bonding points, all conduits and plumbing pipes installed.
 - b) Plumbing pipes must be on soft soil, **or** a bed of sand must be placed underneath the pipe and a pile of sand to backfill must be present at jobsite to pass inspection.
 - c) Water and gas lines must be pressurized. Gas (if applicable): 10psi on a max 15psi gauge. Water: 25psi.
 - [Gas pressure test code reference CPC 318.2 | Water pressure test code reference ISPSC 311.9].
 - Tests on water piping systems constructed of plastic piping shall not use compressed air for the test.
 - d) Verify no access walls will be rebuilt or applicant has access wall permit.
 - e) All non-exempt structures must be listed on the site plan.

2nd Inspection:

- 2) Equipotential bonding grid – Grounding / Bonding (Partial)
 - a) Bonding grid installed per plan and county handout.
 - b) Partial bonding from the 4 points of the pool to the bonding grid.

3rd Inspection:

- 3) Primary Barrier – Grounding / Bonding (Partial)
 - a) Pool barriers and door alarms per plans.
 - b) Rough electrical and bonding to pool equipment.
 - c) **If there is an access wall permit, it must be final prior to or during this inspection (Primary Barrier).**
 - See page 1, note 2 of this “barrier letter”, for further information regarding access walls.

4th Inspection:

- 4) Final – Secondary Barrier – Grounding / Bonding
 - a) Secondary barrier/alarm per plans.
 - b) Complete grounding and bonding.

Failed inspections will result in additional inspection fees, please call when 100% ready.

Incorrect / inconsistent plans or deviation from approved plans will incur corrections and require revisions.



SAM SHAHROURI
DEPUTY DIRECTOR OF
TLMA
BUILDING OFFICIAL

COUNTY OF RIVERSIDE BUILDING AND SAFETY DEPARTMENT

Residential Swimming Pool, Spa, Hot Tub, and Barrier Plan Check Requirements “Barrier Agreement Letter”

The following are drawing examples of typical approved barriers. If there is a conflict between the examples provided below and the “barrier letter” wording, the more stringent provision shall prevail.

VARIOUS POOL FENCE TYPES

(NOT ALL POSSIBLE POOL FENCE DESIGNS ARE SHOWN, PLEASE CHECK WITH YOUR INSPECTOR FOR MORE INFORMATION)

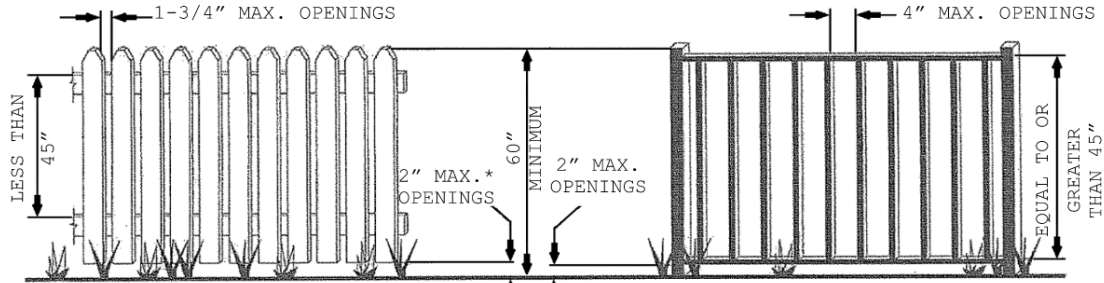

If horizontal members are less than 45" apart, vertical spacing shall not exceed 1-3/4" and horizontal members shall be on pool side.

If horizontal members are equal to or more than 45" apart, vertical spacing shall not exceed 4".

* NOTE: Spacing from grade level to bottom of fence maybe 4 inches if grade below fence has a solid impenetrable surface such as concrete.

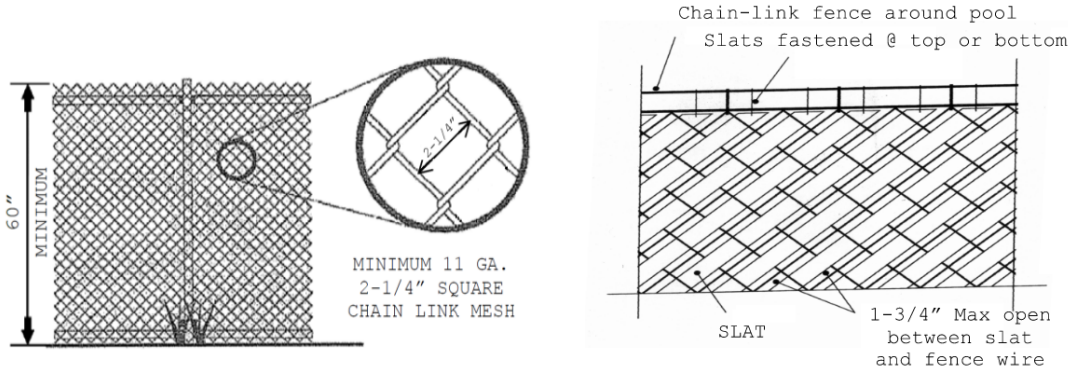

Chain link dimensions at slats in fences around residential swimming pools.
NOTE: If chain link dimensions are larger than shown above, then slats may be woven into the chain link mesh and fastened at the top and bottom

GATE LATCHING REQUIREMENTS

ALL GATES MUST SWING AWAY FROM THE POOL, BE SELF-CLOSING & SELF-LATCHING

Protective shield or fencing with no openings greater than 1/2" Release mechanism shall be located on "pool" side.

Release mechanism may be located On either side If 60"+ above grade.

Release mechanism shall be located at least 60inches above grade.

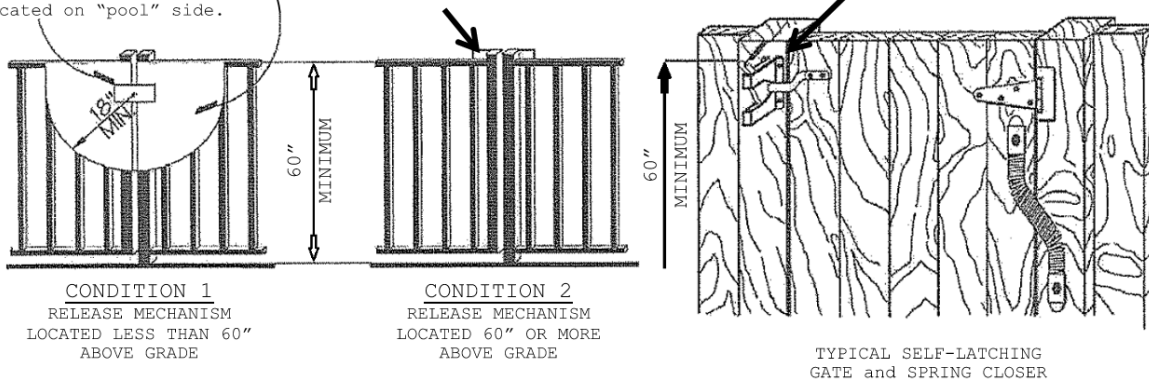



SAM SHAHROURI
DEPUTY DIRECTOR OF
TLMA
BUILDING OFFICIAL

COUNTY OF RIVERSIDE BUILDING AND SAFETY DEPARTMENT

Residential Swimming Pool, Spa, Hot Tub, and Barrier Plan Check Requirements “Barrier Agreement Letter”

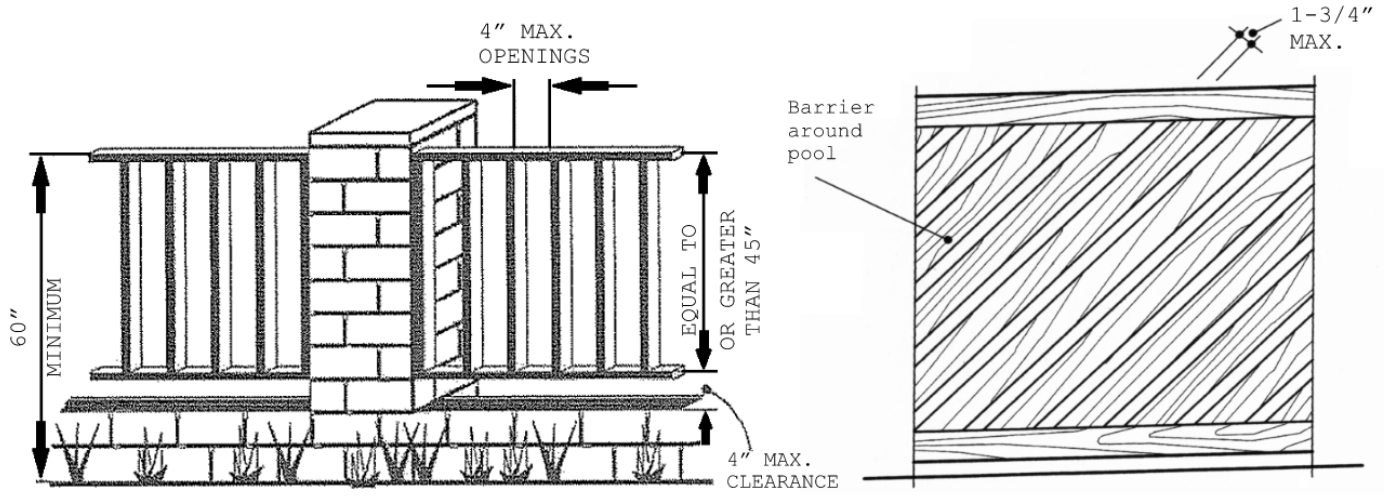

*** NOTE: Spacing from grade level to bottom of fence maybe 4 inches if grade below fence has a solid impenetrable surface such as concrete.**

Diagonal members in barriers around residential swimming pools.

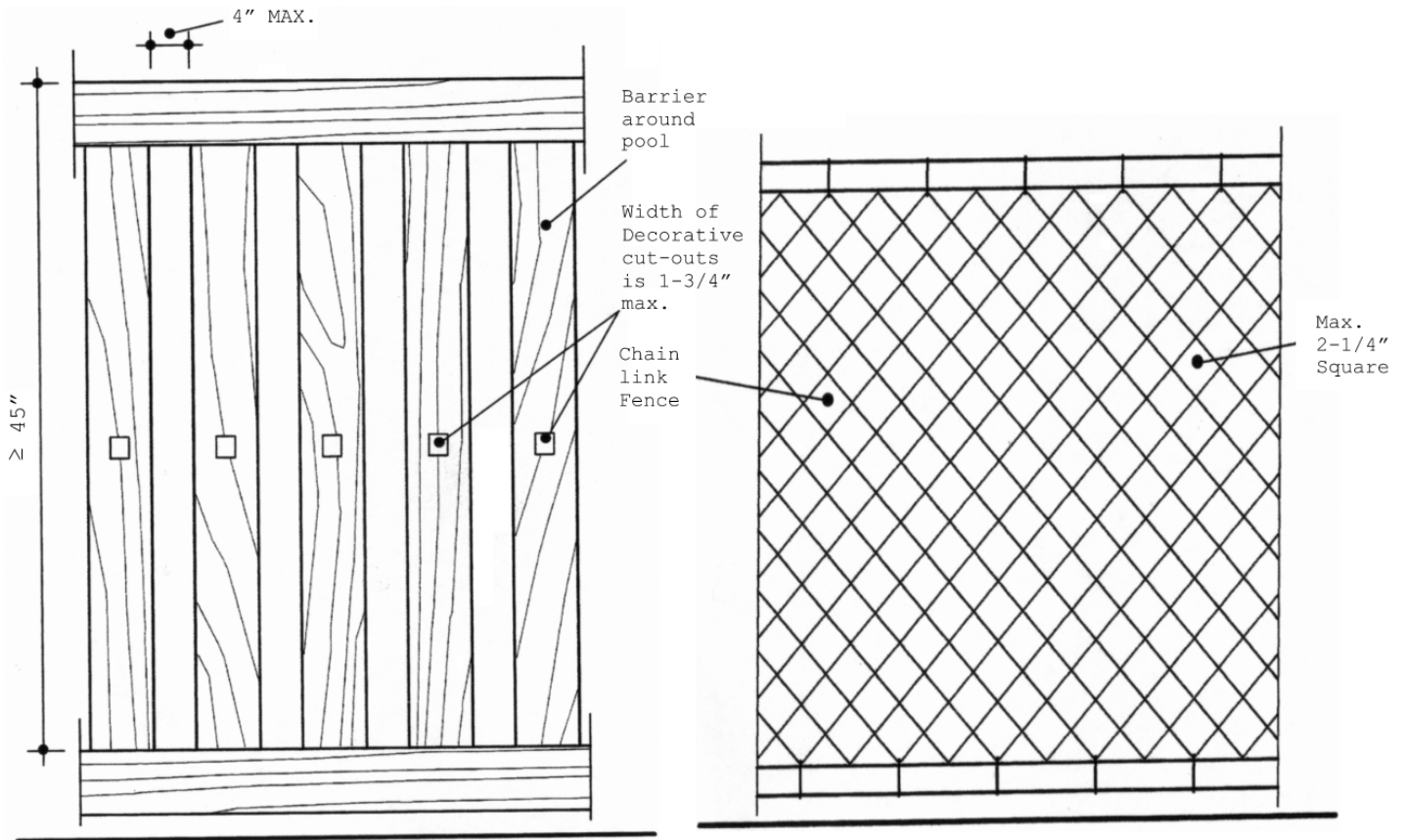

Widely spaced horizontal members in barriers around residential swimming pools

Chain link dimensions in fences around residential swimming pools.